



3mm Surface Mount
Trimmer Capacitors

46 HV Series

Product Features

- High Voltage
- Low Cost Applications
- Low Temperature Drift
- Designed for reflow soldering
- Low Magnetics
- Surface Mount Design
- Half Turn Adjustment
- Tape & Reel Packaging
- RoHS Compliant

Product Applications

- NMR/ MRI Applications/Pre-Amplifiers
- Commercial Instrumentation
- RFID
- Tunable Filter Circuits

Specifications

- Capacitance Range: 1.5pF to 40pF
- DC Working Voltage: 350V
- DC Withstanding Voltage: 770V



Part Numbering

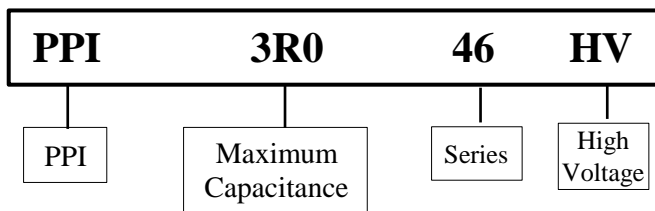

Part Number	PPI3R046HV	PPI6R046HV	PPI10046HV	PPI15046HV	PPI20046HV	PPI30046HV	PPI40046HV
Capacitance (pF)	Minimum 1.5 Maximum 3.0	2.0 6.0	2.0 10.0	3.0 15.0	4.5 20.0	5.5 30.0	8.0 40.0
Marking Color	Black & Green	Blue & Green	White & Green	Pink & Green	Red & Green	Orange & Green	Yellow & Green
DC Working Voltage	350	350	350	350	350	350	350
DC Withstanding Voltage	770	770	770	770	770	770	770
Temperature Coefficient (ppm/°C)	0 ± 200	0 ± 300	0 ± 300	0 ± 500	0 ± 500	-1500 ± 1000	-1500 ± 1000
Q (min.) at 1 MHz	500	500	500	500	500	200	200
Self Resonant Frequency at Maximum Rated Capacitance	2.1 GHz	1.5 GHz	1.16 GHz	0.92 GHz	0.81 GHz	0.70 GHz	0.60 GHz
Insulation Resistance	10 ⁴ megaohms						
Operating Temperature	-40°C to +85°C						
Torque	11 to 72 gf.cm max. 0.14 to 1.0 in-oz max.						
Packaging	All parts furnished on 12mm tape and reel; 1,000 pcs per reel						

Land Pattern Dimensions (inches/mm)

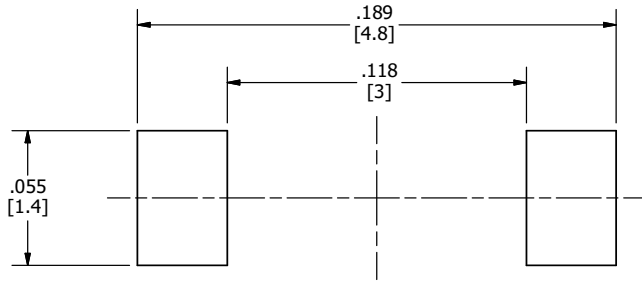

SUGGESTED FOOTPRINT
SOLDER PASTE THICKNESS OF 0.15 [mm] RECOMMENDED

Dimensions (inches/mm)

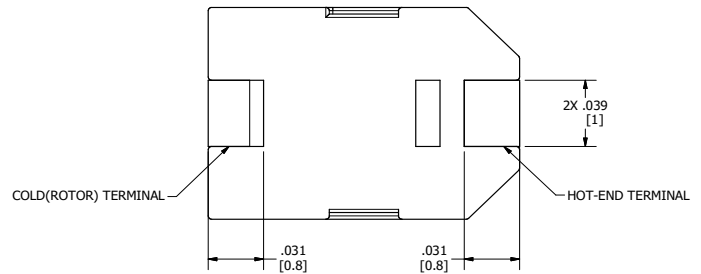

Suggested Soldering Profile

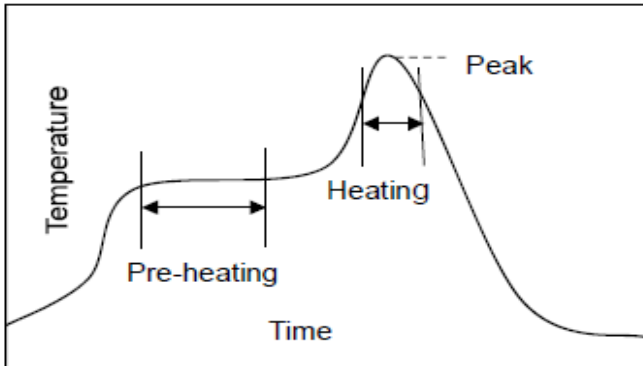

Stage	SAC305 Solder	Eutectic Solder
Pre-Heating	Temp: 150°C - 180°C Time: 60 - 120 Seconds	Temp: 120°C - 150°C Time: 60 - 120 Seconds
Heating	Temp: 220°C Min Time: 30 - 60 Seconds	Temp: 183°C Min Time: 30 - 60 Seconds
Peak Heat	Temp: 265°C Time: 3 Seconds Max	Temp: 265°C Time: 3 Seconds Max
Reflow Cycles	2 Times Max	2 Times Max
Soldering Iron		
Spec	Temperature: 400°C Max Time: 3 Seconds Max	

While PPI makes every effort to provide up to date and complete industry standard information, individual reflow equipment and applications vary. No guarantee is given that the suggested profile is suitable for any application or use.

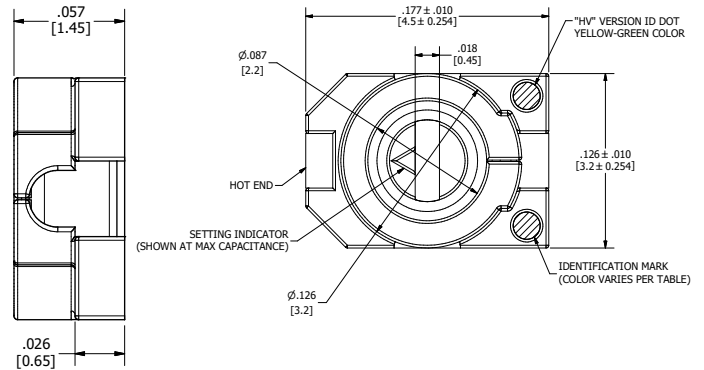

Tape & Reel Specifications

Series	Measurement Unit	W	P0	P1	T	F	Minimum Qty per Reel	Tape Material
46HV	in.	0.472	0.157	0.315	0.012	0.217	1000	Plastic
	mm	12.0	4.0	8.0	0.3	5.5		

A₀K₀

- Determined by component size. Typical clearance between the cavity and the component is: .50 (.002) min to .65 (.026) max for 12mm tape.
- The component cannot rotate more than 20° within the determined cavity.

